



CODEN [USA]: IAJ PBB

ISSN: 2349-7750

**INDO AMERICAN JOURNAL OF  
PHARMACEUTICAL SCIENCES**<http://doi.org/10.5281/zenodo.2628859>Available online at: <http://www.iajps.com>

Research Article

**WAYS TO IMPROVE THE EFFICIENCY OF PRODUCTION  
WHOLE MILK REPLACER.**<sup>1</sup>Lyudmila Kryuchkova, <sup>2</sup>Pavel Shkolnikov, <sup>3</sup>Andrei Burmaga, <sup>4</sup>Ivan Bumbar,  
<sup>5</sup>Alexander Zhirnov<sup>1</sup>Far East State Agricultural University, Polytechnic str., 86, Blagoveshchensk 675005, Russia.**Article Received:** February 2019**Accepted:** March 2019**Published:** April 2019**Abstract:**

*On the basis of the identified problem situation, approaches to the development of an innovative system for preparing a whole milk replacer containing  $\beta$ -carotene, as well as a granulated feed calcium supplement, are scientifically substantiated. The calculated formulas describing the working process of the proposed device are obtained. The composition of the technological line for the implementation of the process with the required performance of machines.*

**Keywords:** whole milk replacer, protein-vitamin base, soybean-root composition, technology, device, scheme, parameters.

**Corresponding author:****Lyudmila Kryuchkova**Far East State Agricultural University,  
Polytechnic str., 86, Blagoveshchensk 675005, Russia.

QR code



Please cite this article in press Lyudmila Kryuchkova et al., *Ways To Improve The Efficiency Of Production Whole Milk Replacer.*, Indo Am. J. P. Sci, 2019; 06(04).

## INTRODUCTION:

One of the main problems associated with the rearing of young farm animals is the use of so-called whole milk replacers (WMR).

Currently, a sufficiently large number of WMR formulations and methods for their preparation are known, which is due to the requirements for the normal growth and development of animals, taking into account the economic aspects of their rearing [1]. A large amount of research is devoted to substantiating the possibility and feasibility of using so-called soy milk as a WMR [1–4].

At the same time, in Japan, it was found that soybean milk exceeds the content of proteins, unsaturated fatty acids, cow's and women's milk [2]. However, for all its advantages, there is no carotene containing vitamins in the composition of soy milk, and its production is characterized by a large yield of perishable so-called. Okara.

In this regard, the actual problem is the creation of WMR on the basis of soybean seeds and carotene plant materials in the form of pumpkin and carrot. The goal of the study is to increase the efficiency of WMR preparation by using soybean- root-vegetable compositions.

Research tasks:

1. To justify the structural-functional scheme of the process and device for the preparation of the protein-vitamin base WMR;
2. Analytically, obtain dependencies that characterize the workflow of the proposed device;
3. To offer a rational constructive-technological scheme of the line for the production of WMR using soybean and root-vegetable compositions.

## MATERIALS AND METHODS:

Analysis of technologies, methods and technical means for the preparation of WMR using soy protein showed that the following are the most common [1, 2]:

- extraction of soy protein from soybean seeds;
- soybean meal or soy flour, both skimmed and nonfat;
- production of soy protein isolates and concentrates by spray drying the proteins extracted according to the first variant.

At the same time, technical tools are used that work on the principle of shock and abrasive effect on the presoaked soybean seeds in the aquatic environment. Figure 1 shows the technological, as well as structural and functional scheme of the process and device for obtaining protein-vitamin bases (PVB) for WMR.

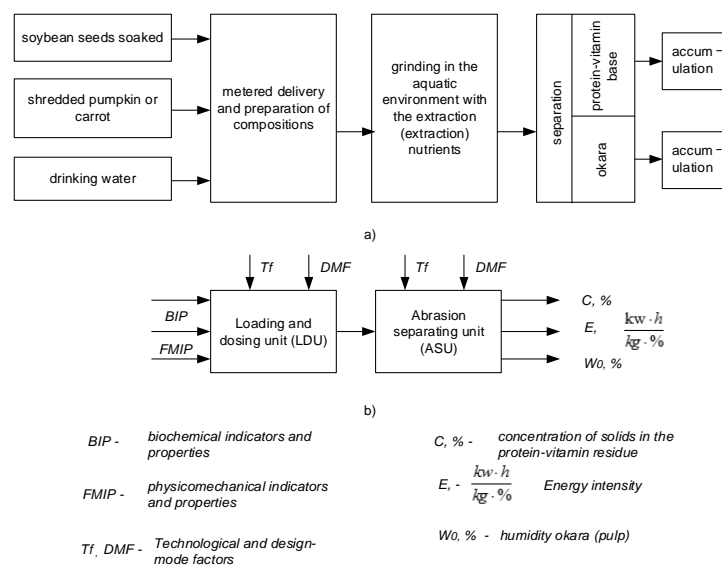

Figure 1: Technological (a) and structural-functional (b) process diagrams and devices for obtaining PVB for WMR

Figure 2 shows the scheme of the proposed device for obtaining PVB for the preparation of WMR.

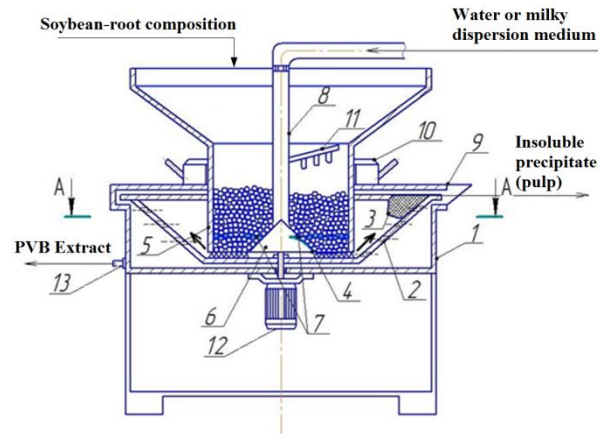

Figure 2: Diagram of the device for cooking SVB: 1 - body; 2 - perforated tapered rotor; 3 - filter; 4 - the base of the rotor; 5 - pipe; 6 - funnel element; 7 - stops; 8 - tube for the supply of the extractant; 9 - reflector visor; 10 - adjusting nut; 11 - metering lever.

### RESULTS AND DISCUSSION:

The output of dry (nutrients) substances in the extractant ( $K_i$ , %), when grinding soybean seeds and particles of root crops (pumpkin or carrot) in devices made according to the type [5-7], obeys the following dependence

$$K_i = K_{IN} \cdot e^{-ct_0}, \quad (1)$$

where  $K_{IN}$  - the initial value of solids in the extractant,%;  $e$  - base of natural logarithm;  $c$  - empirical coefficient taking into account the influence of uncontrollable factors.

The performance of the device on the processed composition is characterized by the following set of parameters

$$Q_y = \frac{V_C \cdot \rho_C \cdot \lambda}{C_1 \cdot \ln\left(\frac{K_i}{K_{fin}} - 1\right)}, \quad (2)$$

where  $V_C$  - volume of compositions,  $m^3$ ;  $\rho_C$  - density composition,  $kg / m^3$ ;  $\lambda$  - degree of grinding particles unit;  $C_1$  - empirical coefficient;  $K_i$ ,  $K_{fin}$  - the current and final solids concentration in the SVB respectively, %.

Humidity detachable pulp -  $W_i$ , using a conical perforated rotor - 2 in ASU (Figure 1 (b), Figure 2) is characterized by the dependence of the following type

$$W_i = W_{IN} \cdot e^{-ct_0}, \quad (3)$$

where  $W_{IN}$  - initial pulp moisture;  $c$  - empirical coefficient;  $t_0$  - spin duration equal to  $2\pi/\omega$  ( $\omega$  - rotor angular speed).

In this case, the energy intensity of the working process of the device can be determined by the dependence

$$E = \frac{100 \cdot N}{Q_y \cdot K_{fin} \cdot \lambda \cdot W_{fin}}, \quad (4)$$

The by-product of the production of PVB is an insoluble soybean-root residue (pulp), which, due to its physico-chemical characteristics, is subject to appropriate processing [5].

Figure 3 shows the constructive-technological scheme of the line for the production of PVB and protein-vitamin-mineral supplements using pulp and calcium-containing component in the form of chalk.

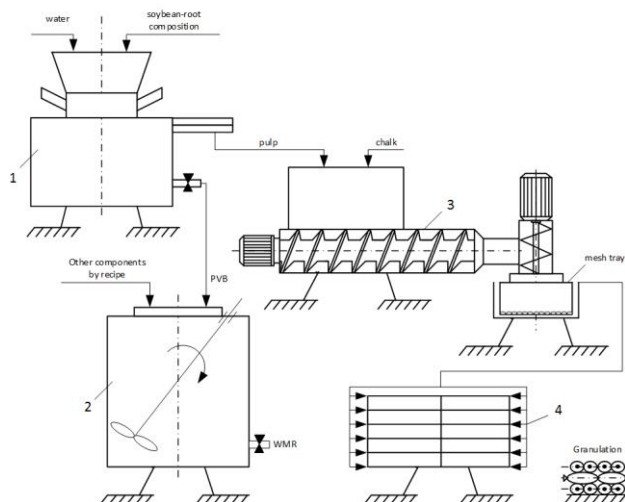

Figure 3: Constructive-technological scheme of the line for the preparation of WMR and granular additives

### CONCLUSION:

On the basis of scientifically based approaches, a structural-functional diagram of the technological process of obtaining WMR and a device allowing the preparation of PVB using soybean and root-crop compositions have been developed.

The obtained formulas for determining the concentration of dry (nutrient) substances in the extractant for a series of innovative technical tools, their performance and energy intensity, taking into account the indicators  $K_{fin}\%$ ,  $\lambda$  and  $W_{fin}, \%$ .

The implementation of this process has established that these indicators, using soy-pumpkin and soy-carrot compositions, are within the following limits:

$$K_{fin} = 11,5 - 12,2\% ; \lambda = 15 - 18 \text{ un. and } W_{fin} = 55-57\%.$$

At the same time, the strength of protein-vitamin-mineral granules - supplements (PVMGS) is 95-96% with  $\beta$ -carotene content in PVB in the range of 0.2-0.5 mg / 100 g and in PVMGS - 1.5-2 mg / 100 g.

### REFERENCES:

1. Gordeziani V.S. 1990. Production of milk replacers. Moscow, Russia: Agropromizdat.
2. Tolstoguzov V.B. 1987. New forms of protein foods. Moscow, USSR: Agropromizdat.
3. Dotsenko S.M., Samuylo V.V., Puchkov N.P. 1995. Mechanization of production of whole milk replacers. Blagoveshchensk, Russia.
4. Smekalov N.A., Zelner V.R. 1976. The use of whole milk substitutes for growing and fattening calves. Survey information. Moscow, USSR.
5. Dotsenko S.M., et al. 2013. The patent of the Russian Federation №2496328. Method of preparation of soy-protein feed products.

6. Dotsenko S.M. et al. 2013. The patent of the Russian Federation №2624947. Wet food shredder.
7. Dotsenko S.M. et al. 2017. The patent of the Russian Federation №2634047. Shredder wet plant products.
8. Varaksin S.V., Dotsenko S.M., Kryuchkova L.G., Burmaga A.V., Markin D.A.. Theoretical substantiation parameters of the process for obtaining a soybean-grain substitute for dairy feed. Research Journal of Pharmaceutical, Biological and Chemical Sciences, 2018; 9(2): 809-816.
9. Varaksin S.V., Dotsenko S.M., Kryuchkova L.G., Burmaga A.V., Markin D.A. Kinematic Aspects For Justifying The Parameters Of The Chamber-Type Tray Dryer. Research Journal of Pharmaceutical, Biological and Chemical Sciences, 2018; 9(3): 814-818.
10. Kryuchkova L.G., Dotsenko S.M., Burmaga A.V., Varaksin S.V., Shkolnikov P.N. Substantiation Of The Method And Parameters Of The Process Of Grinding Root Crops For Lines For The Preparation Of Granulated Forages. Research Journal of Pharmaceutical, Biological and Chemical Sciences, 2018; 9(3): 737-745.